

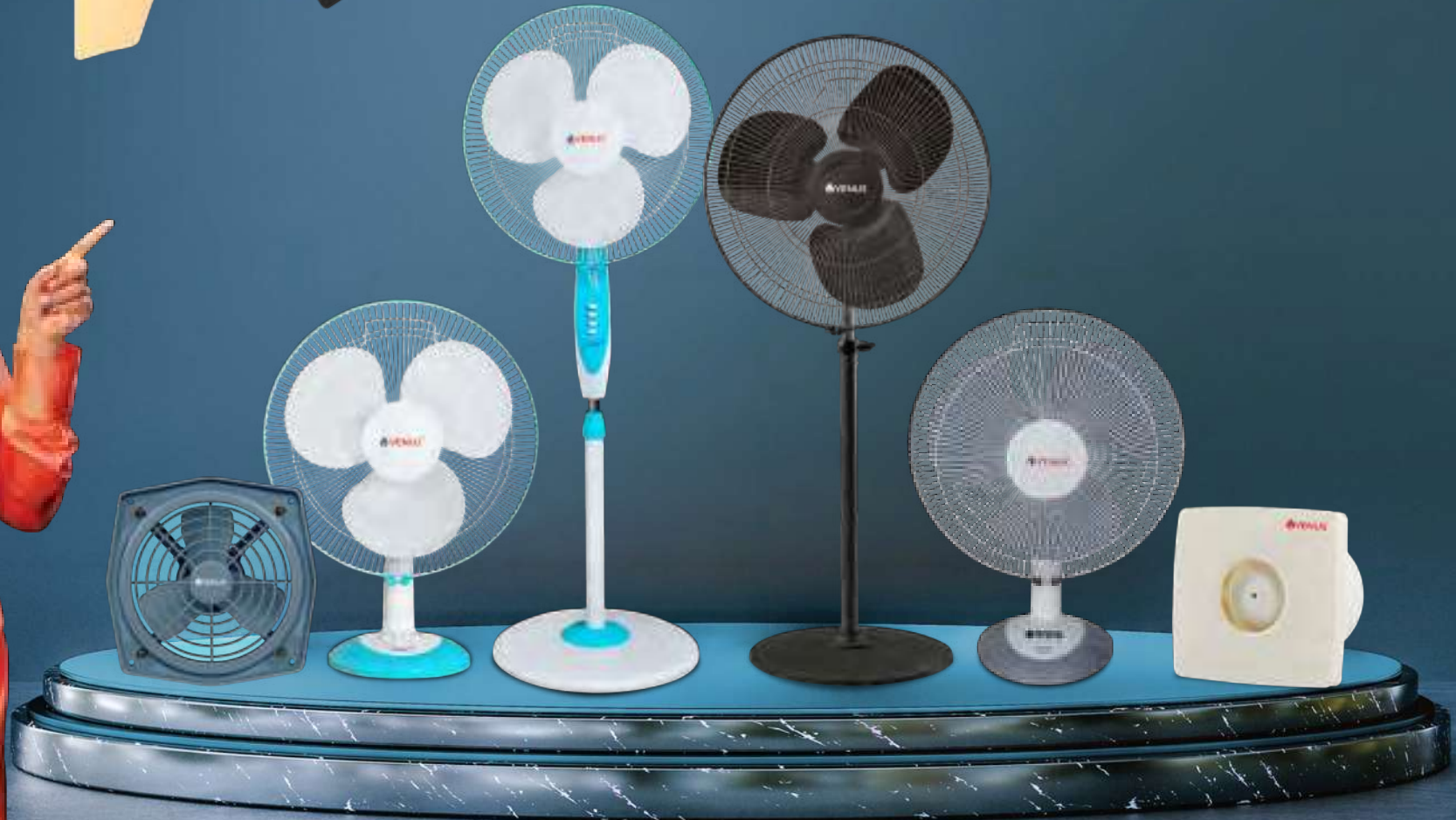

Take home the  
**Breeze!**



# Let there be air!

Over the years, Venus has always pushed the boundaries and brought to you the best of innovation and technology in water heaters. Be it the range, the features or path breaking technology, we have ensured that our products make your lives more convenient.

With the spirit of innovation and quality always at our core, Venus now presents its range of reliable, durable and high speed fans that are popular across all segments. Read on to know more about our range of fans.





## State of the Art Manufacturing Facilities

Our State of the Art Manufacturing facilities at Tuticorin has deployed the most modern technologies, latest Machinery and standardized testing equipment and also the latest manufacturing processes to deliver quality products at the desired level of precision.

## Elevate Comfort, Conserve Energy: Choose BEE Star Rated Ceiling Fans

We are excited to introduce our Venus brand's latest range of ceiling fans, now featuring BEE star ratings for enhanced energy efficiency to experience a new level of energy-saving performance. Our fans are designed to provide superior air circulation while consuming minimal electricity. Make the smart choice – choose Venus Ceiling Fans with BEE star ratings for a perfect balance of comfort and energy savings.

### BIS Certified Ceiling Fans

Ensures Safety and Reliability | Energy Efficiency | Quality Assurance | Compliance and Market Access | Enhanced Brand Reputation | Competitive Edge: In a world where safety and quality are paramount, ISI certification for fans stands as a symbol of excellence. Choose ISI-certified fans for unparalleled safety, reliability, and peace of mind. Join the ranks of trusted venus brand and elevate your fan experience with ISI certification.



Improved Motor for  
lower energy consumption



BEE Certification from  
NABL Approved Labs







BIS Certified  
Ceiling Fans



## Why BLDC Fans ?

BLDC (Brushless DC) motors revolutionize energy efficiency with their advanced design, minimizing friction and energy loss. These motors boast superior performance, delivering precise control and significantly reducing power consumption.

BLDC vs Regular Fan	BLDC	Regular Fan
 Power Consumption	30W	75W
 Usage per day in Hours	16	16
 Energy Consumption per year in kWh	175	438
 Electricity cost per Annum is Rs.	1226	3066



**Annual Savings  
per Fan for a year  
Rs.1840.00**



**Brushless DC Motor  
(BLDC) Technology**



**Consumes only  
30 Watts**



**Seamless operation  
even with Inverter**



**Remote Based  
Speed Control**

**BLDC** Fans have advanced **DC Technology** for trouble free performance and Easy operation

ECO-DRIVE  
**BLDC**  
TECHNOLOGY

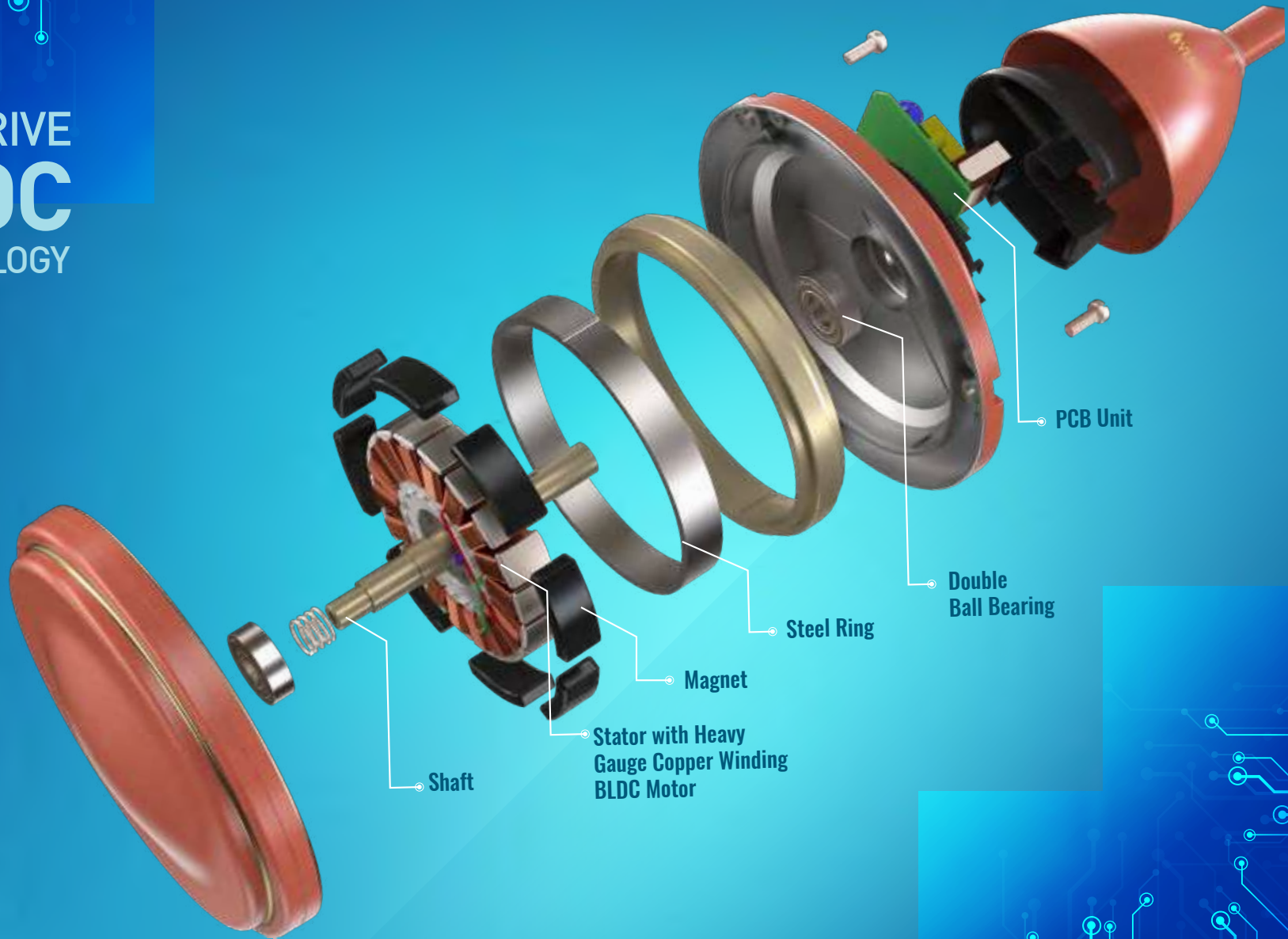

Energy Saving  
60%



Consumes  
Only 30  
Watts

## Halo ABS LED Fans

This Elegant fan comes with a regal design that gives a strong and silent breeze.

Air Craft Propeller Design for Better Air Thrust and Max Air Delivery

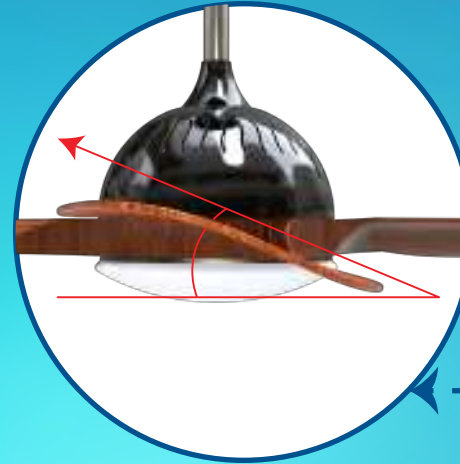

50% more angle than Ordinary Fans for a Strong Breeze

RUST PROOF ABS BLADE WITH PRECISE CURVATURE





**DUST  
RESISTANT**

**DUST-FREE,  
EASY TO CLEAN  
AND CONSISTENT  
FRESH LOOKS**



# Sonic BLDC



Sonic BLDC Fans offer an exceptional solution for those seeking energy-efficient cooling options. With a remarkable 60% energy savings compared to normal fans, they not only reduce electricity bills but also contribute to a greener environment. Beyond their energy-saving benefits, Sonic BLDC Fans boast a stunning design coupled with advanced technology. This combination not only enhances the aesthetics of any space but also ensures optimal performance and functionality.

Model No	Sweep (mm)	Air Delivery (CMM)	Speed (RPM)	Power (Watts)
SB1200	1200mm	220	350	30



Silver White



Cocoa Gold

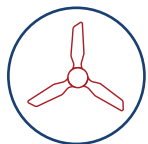

Aerodynamic & Unique Design



Energy Saving 60%



Consumes Only 30 Watts



Dust Resistant

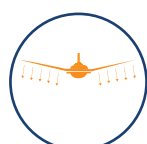

Higher Blade Angle

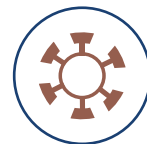

Brushless DC Motor (BLDC) Technology



Electrolytic Grade Copper Winding



Remote Based Speed Control



5 Years Guarantee



# Vector BLDC



Vector BLDC Fans have advanced BLDC technology for trouble free performance and easy operation. This guarantees high speed air delivery and consumption of just 30 watts of power thereby having 60% energy savings compared to Normal Fans. Vector Fans run smoothly and silently even at low voltages or when powered by inverters.

Model No	Sweep (mm)	Air Delivery (CMM)	Speed (RPM)	Power (Watts)
VB1200	1200mm	210	350	30



Matt Brown



Energy Saving  
60%



Consumes  
Only 30 Watts



Remote Based  
Speed Control



100 % pure copper  
winding motor

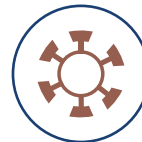

Brushless DC Motor  
(BLDC) Technology



Seamless operation  
even with Inverter



Sensor-less design  
for more reliability



5 Years  
Guarantee



# Sigma BLDC



Sigma BLDC Fan offers high speed air delivery and consumes only 34 watts power with the advanced DC technology. It runs smoothly and silently even at low voltages without any difference in speed. Inverter compatible with no noise, save up to 56% on electricity bills compared to normal fans and enjoy the convenience of remote control operation

Model No	Sweep (mm)	Air Delivery (CMM)	Speed (RPM)	Power (Watts)
SCD1200	1200mm	218	380	34



White



Brown



Consumes Only 34 Watts



Energy Saving 56%



Hi Speed



100 % pure copper winding motor

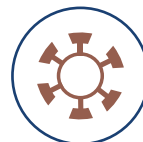

Brushless DC Motor (BLDC) Technology



Seamless operation even with Inverter



Remote Based Speed Control



5 Years Guarantee



**DUST-FREE,  
EASY TO CLEAN  
AND CONSISTENT  
FRESH LOOKS**

# Sonic Pro



Ergonomically designed sleek blades, reliable and durable motor for smooth operation and matchless design makes sonic pro fans the perfect one for your decorative interiors.

Model No	Sweep (mm)	Air Delivery (CMM)	Speed (RPM)	Power (Watts)
SP1200	1200mm	220	400	50



Silver White



Cocoa Gold

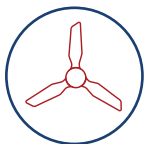

Aerodynamic & Unique Design



Hi Speed



Motor Reliable & Durable



Dust Resistant

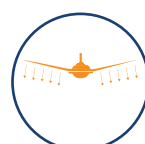

Higher Blade Angle



Sealed Double Ball Bearing



Electrolytic Grade Copper Winding



Higher Air Delivery



2 Years Guarantee

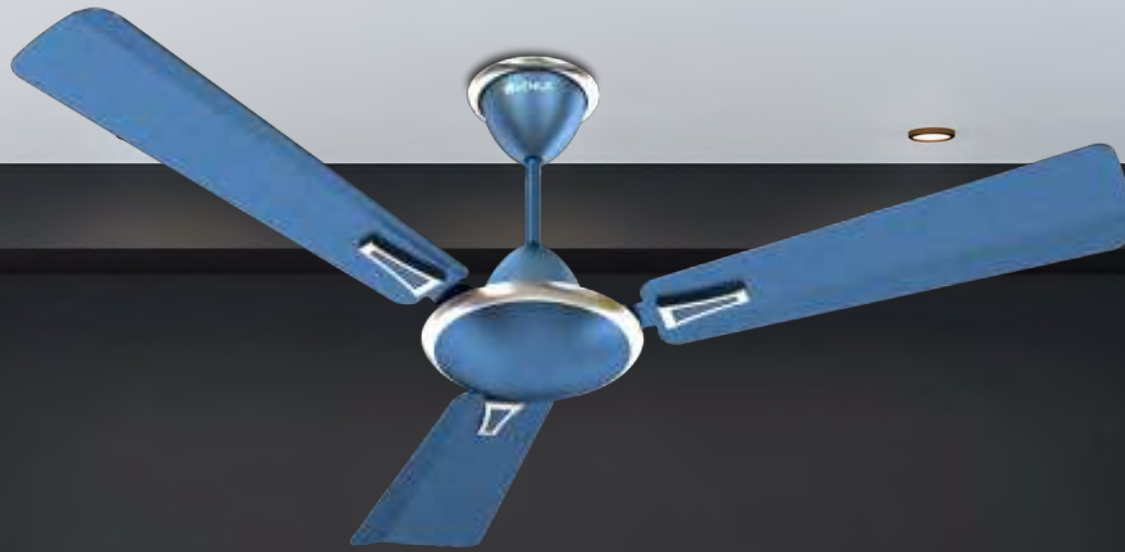

**DUST-FREE,  
EASY TO CLEAN  
AND CONSISTENT  
FRESH LOOKS**





# Adorna



Rust proof construction, metallic 3 layer coating, reliable and durable motor and 100% aluminium body and blades make Adorna fans the perfect choice.

Model No	Sweep (mm)	Air Delivery (CMM)	Speed (RPM)	Power (Watts)
AA1200	1200mm	220	400	50



Gold Shimmer  
(Metallic)



Chestnut Brown  
(Metallic)

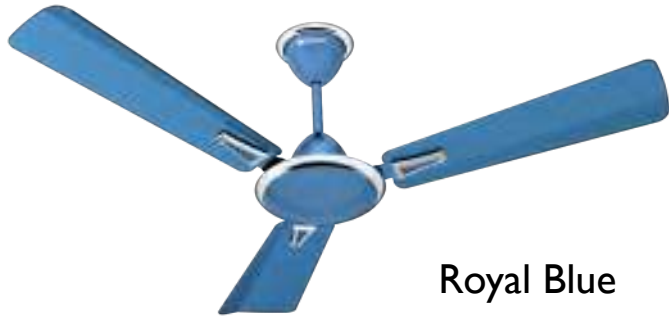

Royal Blue  
(Metallic)



Blush Pink  
(Metallic)



Hi Speed



Metallic with  
Lacquer Finish



Rust Proof  
Construction

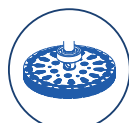

Motor Reliable  
& Durable



Electrolytic Grade  
Copper Winding



Double  
Ball Bearing



Wider  
Air Delivery



Colours Matched  
with Interiors



2 Years  
Guarantee



# Vector Pro



Vector Pro comes with a high speed of 400 RPM, a reliable and durable motor and an assortment of colours that can be matched with your interiors.

Model No	Sweep (mm)	Air Delivery (CMM)	Speed (RPM)	Power (Watts)
VP1200	1200mm	225	400	50



Matt Brown



Brown



White

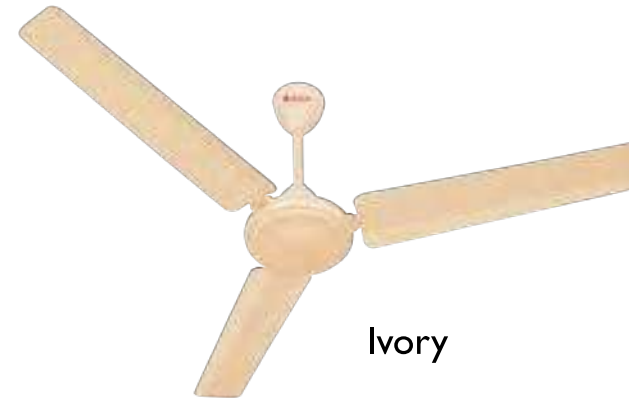

Ivory



Hi Speed



100% Aluminium  
Body and Blade



Double  
Ball Bearing



Motor Reliable &  
Durable



Electrolytic Grade  
Copper Winding



Wider  
Air Delivery



Colours Matched  
with Interiors



2 Years  
Guarantee



# Matrix Deco



Matrix deco fan from Venus is a style icon with stylish trims. It is made with 100% aluminium body and blades which makes it rust-proof and durable. It has wider blades that provide higher air delivery.

Model No	Sweep (mm)	Air Delivery (CMM)	Speed (RPM)	Power (Watts)
MD1200	1200mm	210	400	50



White



Brown



Black Gold



Stylish Design



100% Aluminium Body and Blade



Hi Speed



Motor Reliable & Durable



Electrolytic Grade Copper Winding



Wider Air Delivery

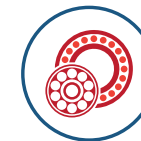

Double Ball Bearing



2 Years Guarantee



# Matrix Pro



The Matrix Pro collection, with wider blades for high air circulation and 100% Aluminium body and blades offers maximum comfort at minimum prices

Model No	Sweep (mm)	Air Delivery (CMM)	Speed (RPM)	Power (Watts)
MP1200	1200mm	210	400	50



Brown



White

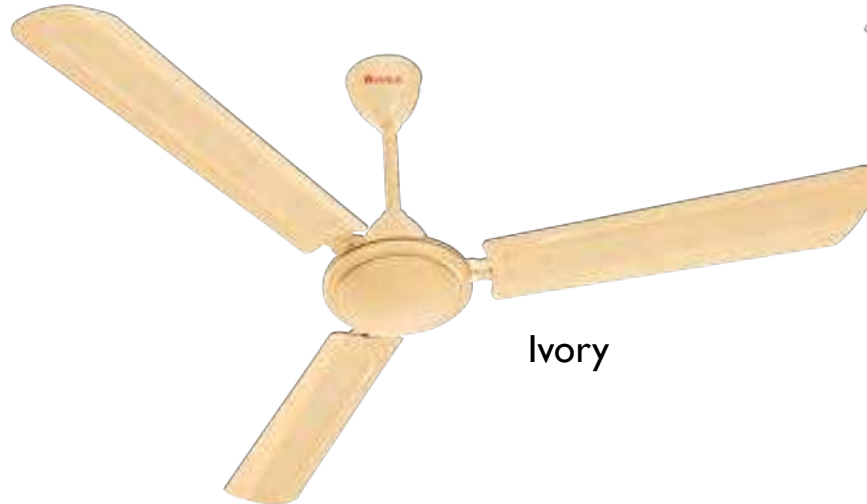

Ivory

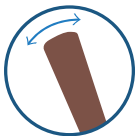

Wider Blade  
High Air Circulation



Hi Speed



100% Aluminium  
Body and Blade



Electrolytic Grade  
Copper Winding

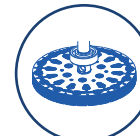

Motor Reliable &  
Durable



Double  
Ball Bearing



Colours Matched  
with Interiors



2 Years  
Guarantee

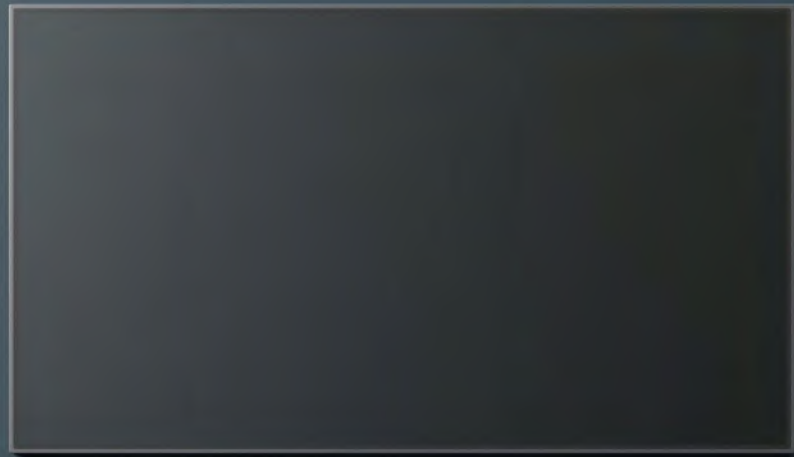



# Zapper



Zapper fans offers high cool breeze in the most reliable way.  
Available in an elegant design and colours to suit your Home decor.

Model No	Sweep (mm)	Air Delivery (CMM)	Speed (RPM)	Power (Watts)
ZC1200	1200mm	210	390	50



Brown



Ivory



White



Colours Matched with Interiors



Hi Speed



Galvanized Blade



Wider Air Delivery



Motor Reliable & Durable



Electrolytic Grade Copper Winding



Double Ball Bearing



2 Years Guarantee



**NEW**



1000 WINES  
HOME COOKING  
TOKYO

MODERN ART  
RECORD OF  
MODERN ART



# Zing Air



Zing Air fans offers high cool breeze. yet another beauty to suit your interiors.

Model No	Sweep (mm)	Air Delivery (CMM)	Speed (RPM)	Power (Watts)
ZA1200	1200mm	210	390	50



Brown



White



Ivory



Colours Matched with Interiors



Wider Air Delivery



Hi Speed

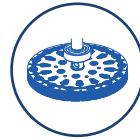

Motor Reliable & Durable



Electrolytic Grade Copper Winding

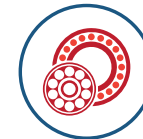

Double Ball Bearing



2 Years Guarantee



# Halo

Halo ABS LED Fans comes with the convenience of ABS Blade and LED light easily controlled by remote. This Elegant fan comes with a regal design that gives a strong and silent breeze.

Model No	Sweep (mm)	Air Delivery (CMM)	Speed (RPM)	Power (Watts)
HPL1200	1200mm	230	300	90+15



Deep Wood Grain



Air Craft Propeller Design



Wider Air Delivery



15W LED Light



Rust Proof ABS Blade

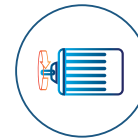

Powerful Motor



Reverse Option Warmth & Comfort



2 Years Guarantee



# Novella

The stylish Novella is an elegant fan with an exquisite combination of striking design and splendid looks. This classic fan gives the experience of strong and silent breeze over a larger area powered by inclined abs blades.

Model No	Sweep (mm)	Air Delivery (CMM)	Speed (RPM)	Power (Watts)
NP1200	1200mm	240	300	75



Pearl White



Hazel Brown



Aerodynamic design blades for greater air delivery



Strong & Silent Operation



ABS Blades - Rust Proof Construction

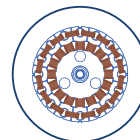

18 Pole Powerful Motor



Higher Air delivery



Striking Design, PU Coated for premium finish



2 Years Guarantee





# Farrata Fans

Farrata Fan from Venus is distinctively designed to provide Power packed performance with stylish metallic looks. Elegant design, Rust proof body and blades, Dynamically balanced metal blade makes it a completely sturdy model. Heavy weight, Extra strong motor, Attractive corrosion resistant metallic finish and Rust proof wire guards. Overall it is a stylish high speed pedestal fan.



## CYCLO

**Model : CF500 / CFO500**

- Aluminium Blade for long life
- Heavy duty extra strong motor sturdy metal construction
- 500 mm sweep • 140W Power
- 1350 RPM • 140cm Air Delivery
- Elegant Design • 3 Speed options
- Large & heavy base for stability
- Oscillation Provided (CFO500 Model only)



## CYCLO

**Model : CFO400**

- Engineering Plastic Blade
- Heavy duty strong motor sturdy metal construction
- 400mm sweep • 115W Power
- 2400 RPM • 95 cm Air Delivery
- Elegant Design • 3 Speed options
- Large & heavy base for stability
- Over Heat Protection
- Oscillation Provided



**Heavy Duty  
Motor**

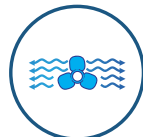

**Aluminum Blade  
Higher Air Delivery**



**3 Speed  
Regulator**



**Rugged  
Durable**



**2 Years  
Guarantee**



# Pedestal Fans

This range is available in regular and Hi-speed models. Light but sturdy construction. Place anywhere for a strong and cool breeze.



## SWAY Hi-Speed Fan

Model : SHP400

- 400 mm sweep • 120W Power
- 2250 RPM • 85cm Air Delivery
- Elegant Design • 3 Speed options
- Strong air delivery • Jerk free
- Large & heavy base for stability
- Temperature Overload Protection
- Oscillation Provided



## SWAY<sup>+</sup>

Model : SPF400

- 400 mm sweep • 60W Power
- 1350 RPM • 65cm Air Delivery
- Elegant Design
- Jerk free
- 3 Speed options
- Oscillation Provided
- Available colour White and Sky Blue



**Hi Speed**  
2250 RPM



**Jerk Free**  
Wide Oscillation

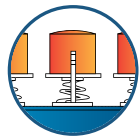

**Piano Switches**  
for Speed Control



**Elegant Design**



**3 speed options**



**Large & Heavy**  
base for stability

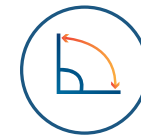

**Oscillation**  
Provided



**2 Years**  
Guarantee



# Table Fans

Table top models for convenient operation. Available in regular and Hi-speed models. Perfect way to cool down in hot summer.

## SWAY Hi-Speed Fan



- Model : SHT400
- 400 mm sweep • 120W Power
  - 2250 RPM • 85cmm Air Delivery
  - Elegant Design
  - Strong air delivery
  - Piano switches for speed control
  - 3 Speed options
  - Temperature Overload Protection
  - Oscillation Provided

## SWAY<sup>+</sup>



- Model : STF-400
- 400 mm sweep • 60W Power
  - 1350 RPM • 65cmm Air Delivery
  - Elegant Design
  - 3 Speed options
  - Oscillation Provided
  - Available colour White and Sky Blue



Hi Speed  
2250 RPM



Rust Proof  
PP Blade



Piano Switches  
for Speed Control



Elegant Design



3 speed options



Oscillation  
Provided



2 Years  
Guarantee



# Wall Fans

Simple and elegant design to match your interiors. In regular and Hi-speed fans with wider air delivery.

## SWAY Hi-Speed Fan



- Model : SHW400
- 400 mm sweep • 120W Power
  - 2250 RPM • 85cm Air Delivery
  - Elegant Design
  - Strong air delivery
  - 3 Speed options
  - Temperature Overload Protection
  - Oscillation Provided

## SWAY<sup>+</sup>



- Model : SWF400
- 400 mm sweep • 60W Power
  - 1350 RPM • 65cm Air Delivery
  - Elegant Design
  - 3 Speed options
  - Temperature Overload Protection
  - Oscillation Provided
  - Available colour White and Sky Blue

• 2250 RPM



**Hi Speed**  
2250 RPM



**PP Blade**  
Higher Air Delivery



**2 Years**  
Guarantee



**Elegant Design**



**3 speed options**



**Large & Heavy**  
Base for stability



**Oscillation**  
Provided



# Exhaust Fans

Rejuvenate your kitchen and bathrooms with fresh air in minutes. Stylish and modern design to match the interiors.





# Fresh-X

Vestra exhaust fans are made from strong and rust proof ABS plastic. Louvre type design for privacy & protection from wind, rain and dust. Simple and easy to install design.



FPE150 / FPE200 / FPE250

Model No	Sweep (mm)	Air Delivery (CMM)	Speed (RPM)	Power (Watts)
FPE150	150 mm	9.00	2400	50
FPE200	200 mm	8.60	1290	45
FPE250	250 mm	14.30	1290	45

# Axial



AVF 150

Model No	Sweep (mm)	Air Delivery (CMM)	Speed (RPM)	Power (Watts)
AVF150	150 mm	4.30	2100	25

# Exair

Exair exhaust fans are great for the kitchen to exhaust the oily fumes and odour. Keeps the kitchen fresh at all times. Rugged construction ensures reliable performance for years.



EBB225/300

Model No	Sweep (mm)	Air Delivery (CMM)	Speed (RPM)	Power (Watts)
EME225	225 mm	10.00	1350	32
EME300	300 mm	20.00	1350	38

- High Performance Motor for Hi-Air Throw
- Bush Bearing
- Sturdy Metal Body and Blade
- Rust Proof Plastic Bird Guard



100% Copper Coil  
Reliable Motor



Easy Installation  
Mounting Bracket

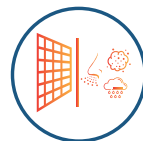

Protection  
Dust, Smell & Rain

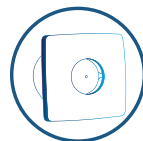

ABS Body  
Long Life & Durable

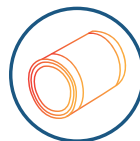

Bush Bearing



Thermal Overload  
Protector

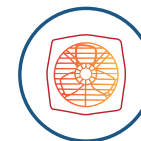

Metal Body  
Long Life & Durable

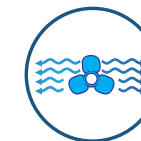

Metal Blade  
Higher Air Delivery

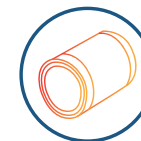

Bush Bearing



2 Years  
Guarantee

## Guidelines for Selection of ceiling fans

Recommended Minimum Fresh Air Supply refer the figure 1 below :

Air Space/Person	Air Supply/Person	Air Changes/Hour
3 m <sup>3</sup>	61 m <sup>3</sup> /Hour	20
6 m <sup>3</sup>	40 m <sup>3</sup> /Hour	6.5
9 m <sup>3</sup>	29 m <sup>3</sup> /Hour	3.2
12 m <sup>3</sup>	21 m <sup>3</sup> /Hour	1.8

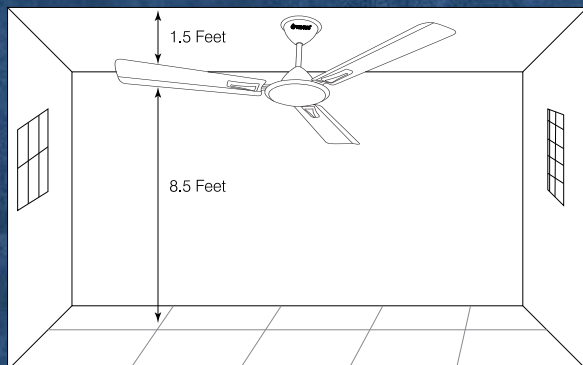

Fig. 1

For large hall, auditoriums, offices, install two or more ceiling fans with a space as specified refer the figure 2 below :

Sweep of fan	Center Distance
900 mm (36")	6 feet (1.82 mtrs. approx)
1050 mm (42")	7 feet (2.13 mtrs. approx)
1200 mm (48")	8 feet (2.43 mtrs. approx)
1400 mm (56")	10 feet (3 mtrs. approx)

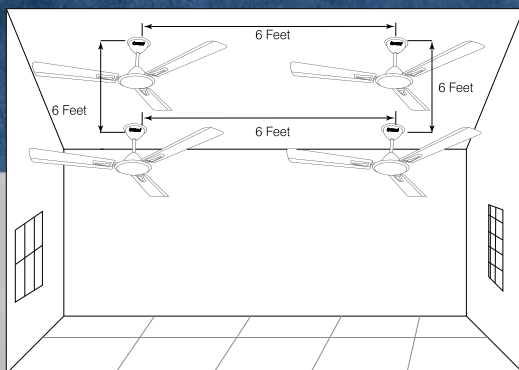
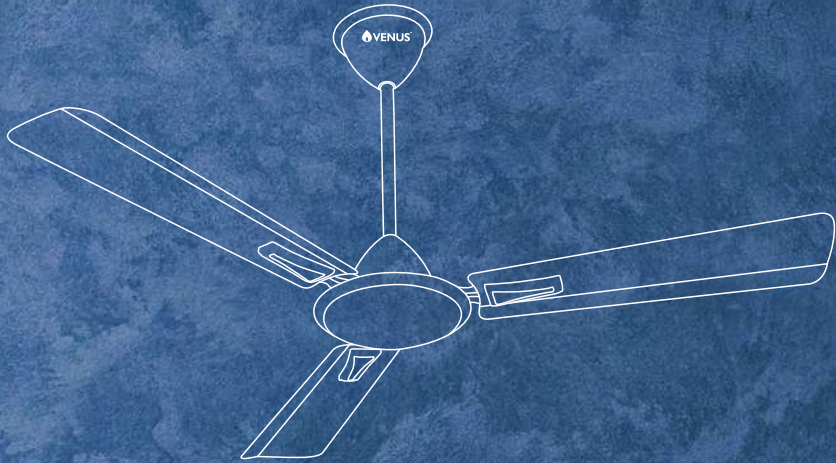

Fig. 2

General Guidelines for Ceiling Fan & Exhaust Fan		
Model	Sweep (MM)	Suitable For Room Size
Ceiling Fan	600mm (24 Inch)	For small shops, Cabins, Toilets
Ceiling Fan	900mm (36 Inch)	2.1 x 3.1 m (7 x 10 feet)
Ceiling Fan	1050mm (42 Inch)	3.1 x 3.1 m (10 x 10 feet)
Ceiling Fan	1200mm (48 Inch)	3.7 x 4.0 m (12 x 13 feet)
Ceiling Fan	1400mm (52 Inch)	4.3 x 4.9 m (14 x 16 feet)
Domestic Exhaust Fan	150mm (6 Inch)	1.8 x 1.8 x 2.7 m (6 x 6 x 9 feet)
Domestic Exhaust Fan	200mm (8 Inch)	1.8 x 1.8 x 2.7 m (6 x 6 x 9 feet)
Domestic Exhaust Fan	225mm (8.8 Inch)	2.4 x 2.4 x 2.7 m (8 x 8 x 9 feet)
Domestic Exhaust Fan	300mm (12Inch)	3.1 x 2.4 x 2.7 m (10 x 8 x 9 feet)

### Selection Criteria and Recommended Minimum Fresh Air Supply Selection Criteria For Exhaust Fans

Area	Air Changes Per Hour
Storage Area/Residence	1.0 - 2.0
Class rooms/Libraries	2.0 - 4.0
Assembly Hall/Labs	4.0 - 6.0
Bars/Hospital ward/Lavatories	6.0 - 8.0
Garages/Theaters/Workshops	6.0 - 10.0
Cafes/Canteens	8.0 - 12.0
Restaurants/Laundries	10.0 - 15.0
Bakeries/Canteen Kitchens	15.0 - 30.0
Engine Rooms/Boiler Houses	15.0 - 30.0
Foundries & Furnace Rooms	30.0 - 60.0



# A SERVICE THAT'S FULL OF WARMTH

Venus designs its products to meet demanding national and international standards. You can be sure that this drive for quality is matched by the customer satisfaction record that our after sales service strives for. "Service within 24 hours" is the promise of our committed service personnel. With more than 300+ service centers throughout the country, prompt, economical and reliable service will reach you, wherever you are.



For service with warmth  
Call Customer Care

 **08144666999**

 **09884064999**



Service in  
24 hours



Genuine  
spare parts



Nationwide  
Service



## **VENUS HOME APPLIANCES (P) LTD.**

**CENTRAL MARKETING OFFICE:** 4/993, Kamaraj Street,  
Rajiv Gandhi Salai (OMR), Kottivakkam, Perungudi Post,  
Chennai - 600 096. Ph: 4340 1515

**Customer Care:** 08144666999 | **Whatsapp:** 09884064999

**Email:** [customercare@venushomeappliances.com](mailto:customercare@venushomeappliances.com)

**Website:** [www.venushomeappliances.com](http://www.venushomeappliances.com)

